



Quality and Reliability, Since 1932!

VAPOR VENTS

PRESSURE VACUUM VENT

Application -

Vapor recovery applications to assure even pressure in the UST during filling or dispensing.

Part Number - 46



UNIVERSAL
Advantage

Only Universal provides rugged all cast metal construction...built to last. This eliminates any injuries due to sharp corners and edges, unlike competitive fabricated products.

Features -

- ✓ Restricts vapor escape during product drops
- ✓ Vent slips onto existing vent piping and is held in place by 3 set screws (Model 46-2080 has 2" NPT threads)
- ✓ CARB certified
- ✓ Conforms with NFPA-30

Construction -

- All cast aluminum body
- Flame retardant 40 mesh bronze screen

Model	Size	Weight (lbs.)	Dimensions		Vacuum	
			A	B	Pressure	{oz}
46CS-2080	2"	2	5-7/8"	4-1/4"	2" Water Col.	0.5
46CS-3080	2"	2	5-7/8"	4-1/4"	3" Water Col.	0.5
46-2080	2"	2	5-7/8"	4-1/4"	8 oz.	0.5
46S-2080	2"	2	5-7/8"	4-1/4"	8 oz.	0.5
46P-3L	3"	3.5	6"	4-1/4"	2" Water Col.	0.5

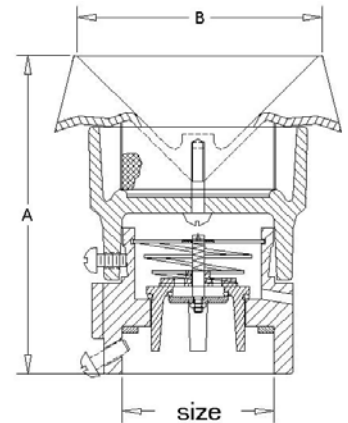

Notice: Universal Valve Co., products must be used in compliance with applicable federal, state, and local laws and regulations. Product selection should be based on physical specifications and limitations and compatibility with the environment and material to be handled. Universal Valve Co., makes no warranty of fitness for a particular use. All illustrations and specifications in this literature are based on the latest production information available at the time of publication. Prices, materials, and specification are subject to change at any time, and models may be discontinued at any time, in either case, without notice or obligation.

UNIVERSAL VALVE COMPANY

478 Schiller Street, Elizabeth, NJ 07206 • (800) 223-0741 • (908) 351-0606 • Fax: (908) 351-0369 • universalvalve.com

© 2003 Universal Valve Company, Inc.