



safety. compliance. reliability.

Features

- UL343 Pumps
- Duplex Strainer
- Differential Pressure Gauge
- Inlet and Outlet Ball Valves and Gauges
- Containment Base with Leak Detector
- Pressure Relief Valves (2)
- Integrated Pump Priming Ports
- Pressure and Flow Sensors (2)
- Intergraded Controller Support System
- Intergraded Controller, FOC-FOS, CMFTS
- Intergraded Fuel Maintenance System
- Stainless Steel Piping
- Factory Tested to 100# for 24hrs



SafeSite™ Duplex Pump Sets

Reliable Fuel Transfer

The Duplex Pump Set is designed for reliable fuel transfer in emergency power systems at critical facilities. Its innovative compact design has a minimal footprint while delivering 5 to 30 GPM of fuel to serve emergency generators and boilers.

The mechanical design is based on Viking positive displacement pumps and is complete with strainers, check valves, ball valves, pressure/vacuum gauges, and relief valves. The unit is mounted on an integral containment with leak detection monitoring.

The Duplex Pump Set includes an FOC or CMFTS Control Panel, or optional VFD drive, with disconnect switch. The FOC or CMFTS controller provides duplex pump operation and monitoring with HOA switches and an emergency stop. The Controller networks with other system controllers using Ethernet, and directly to Building Management Systems with an option of BACnet or Modbus.

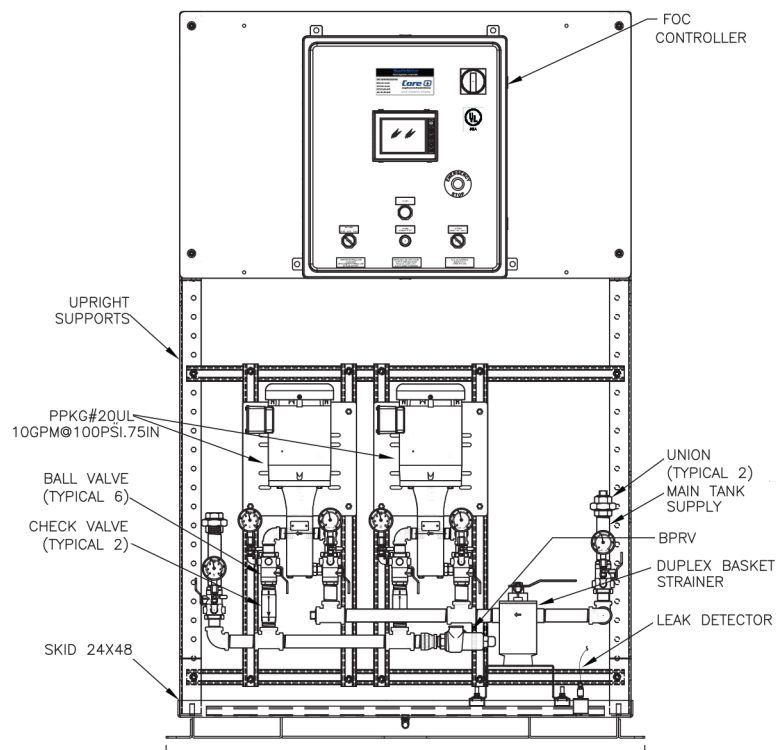

CMFTS Duplex Pump Set with Duplex Filtration, Day Tank, and Return Pump



CMFTS Duplex Pump Set

