



**Oldcastle®**  
*FuelVaults™*

# FuelVault Field Installation Manual



*safety. compliance. reliability.*

*Distributed by:  
Core Engineered Solutions, Inc.  
620 Herndon Parkway, Suite 120*

*Herndon, VA 21070*

*800.826.5472*

## **INTRODUCTION**

The purpose of this manual is to provide specifiers, owners and contractors with detailed instructions on installing Oldcastle FuelVault “at” and “below grade” fuel containment vaults and related accessories.

Note: Oldcastle FuelVault installation is a very specialized business. If you do not have the proper experience, please contact a contractor who does, or call Oldcastle Precast, Inc. for a list of experienced contractors.

## **THIS INFORMATION IS IMPORTANT!**

### **PROPER INSTALLATION OF EACH FUELVAULT IS ESSENTIAL:**

- TO ENSURE THE SAFETY OF ALL THE INDIVIDUALS INVOLVED IN THE FUELVAULT SYSTEM INSTALLATION
- TO PREVENT FUELVAULT & TANK DAMAGE AND/OR FAILURE, WHICH COULD LEAD TO PRODUCT LOSS AND ENVIRONMENTAL CONTAMINATION
- TO VALIDATE THE OLDCASTLE FUELVAULT WARRANTY

**Important Reminders:**

- Oldcastle FuelVaults must be installed according to these instructions and Uniform Fire Code (UFC)

Appendix II-J of the 1995 Supplement to the UFC and NFPA 30A, latest editions.

- Any variances to the published Installation Instructions must be approved by Oldcastle Precast, Inc. **in writing *prior to the installation***.
- Safety requirements shall be in accordance with all federal, state and local regulations; it is the responsibility of the installer to consult them.
- The presence of an Oldcastle Precast, Inc. representative at the jobsite does not relieve the installer of responsibility to follow these published installation instructions.

---

**In order to Activate the FuelVault Limited Structural Warranty:**

- These instructions must be followed.
- Oldcastle's Installation Checklist (provided to you ) must be filled out completely, signed by both the installer and owner, and **the original checklist submitted and received** by Oldcastle Precast, Inc., to validate any future warranty claims.

# **FUEL VAULT INSTALLATION INSTRUCTIONS**

## **Before You Begin:**

- Read, understand and follow these instructions.
- Barricade the FuelVault installation area as required by local safety / traffic regulations.
- Complete the FuelVault installation checklist (Pub. # FV-9602). The fully filled out and signed original must be submitted and received by Oldcastle Precast, Inc. to validate any future warranty claim.

- Check with local authorities for permitting, phased installation inspections, and final inspection approvals, etc., if required.
- If you have questions on installation details, and/or FuelVault modifications that need to be done in the field, contact your local Oldcastle FuelVault representative. Approval of any modifications to the factory built FuelVault must be made in writing by an authorized Oldcastle Precast, Inc. representative in order for the FuelVault limited warranty to be valid.

---

## **1. Handling, Lifting and Setting**

- The customer is responsible for properly rigging, lifting and setting the FuelVault sections..
- Use ONLY lifting gear engineered and built to safely lift each FuelVault section. Special lifting gear may be needed; your Oldcastle representative will provide information on what gear is required to safely lift and set each section of the vault structure. The FuelVault sections shall only be lifted at the lifting points so designated by Oldcastle Precast, Inc.

## **2. Excavation Size and Clearance**

- The excavation and any required shoring and/or sloping must allow for the overall dimensions of the FuelVault (including any engineered appurtenances such as anti-flotation aprons) and all setting and lifting gear.
- The FuelVault must be set to within 1/4" of specified finished grade.
- When computing the depth of the excavation, consider the additional height of the bedding material and any accessory equipment to be set on the FuelVault top section (subpump sumps, manway riser rings, etc.)
- A minimum clearance of 2'-0" must be provided between the FuelVault exterior walls and any obstructions, to allow workers to walk completely around the structure for removal of lifting gear and guide angles.

## **3. Bedding Preparation**

- Bedding material shall be placed on undisturbed, nonexpansive earth or compacted fill, free of organic material, compacted to 95% relative compaction, with an allowable soil bearing pressure of 2,000 p.s.f. minimum. NOTE: a geotechnical engineer should evaluate the effect of a high water table or any other unusual soil conditions.
- Bedding materials: Clean graded sand, crushed rock, or pea gravel are approved in dry compacted excavated bases. Bedding material (6" minimum depth) shall be placed, screeded, compacted and leveled to within 1/8".
- SHORING: If the excavation site soil is unstable or saturated, shoring may be required. It is the customer's responsibility to meet all federal, state and local safety codes and regulations for excavation, sloping and shoring.

#### **4. Setting the FuelVault Base Section**

- Raise the structure off the transport trailer making sure the section is level and being lifted straight. CAUTION! Lifting the base section with the lifting cables at even a slight angle could cause the section to suddenly shift sideways as it lifts off the deck, striking the trailer gooseneck, etc.
- Lower the base section into the prepared excavation making sure it is correctly positioned with above grade offsets and final positioned measurements. Set the base section onto the prepared bedded base material.
- Before removing the lift gear & cables, make sure the base is seated level and the base of the structure is not sitting on any high or low points. If high or low points are detected, remove the base from the excavation and re-grade the bedding material to a level grade, before repeating the setting steps above.
- Remove the lift cables and then the lift gear. Fill any lift inserts or recesses with non-shrink grout and, coat over exterior grouted area with bituminous waterproof coating.

#### **5. Setting Tank In The FuelVault**

Only tanks built to UL 142 standards and displaying the UL Listing label shall be installed in Oldcastle FuelVaults.

- Set UL 142 fuel tank using proper lifting equipment.
- Use all lifting lugs provided on tank top.
- If precast tank anchors have been provided in the FuelVault base section, set tank as close as possible to eliminate the need to shift tank on vault floor, which will reduce scratching epoxy coating.
- It is best to install piping through vault hole penetrations before permanently anchoring tank to floor; this will allow you to shift the tank, as needed, to match openings.

## 6. Installing the Joint Sealant (Figure 1)

- A special primer has been factory applied to the joint of both FuelVault sections; thoroughly clean the entire joint area prior to applying the sealant.
- The joint sealant specified on Oldcastle project drawings must be applied on the base joint as shown in the attached Figure 1
- **NOTICE:** Never start the sealant roll at a corner

Never overlap the end of one roll and the beginning of another.

Always butt the two pieces and knead them together

Never leave any open gaps in the sealant application.

- Press the sealant firmly onto the joint surface before removing the plastic protective covering.
- You are now ready to set the top vault section on the base section.

## 7. Setting the FuelVault Top Section (Figure 2)

- If guide angles have been provided, install on FuelVault corners as shown in Figure 2. The guides will allow the top section to be more accurately set into the joint pocket as the section is lowered into place.
- Attach at least two guide ropes, to help maneuver the section in place for lowering.
- Proper lifting equipment and gear must be used to assure the top section is picked and set level; this is critical so the top section joint touches the base joint in all places at the same time, assuring a complete and thorough seal.

**IMPORTANT!!** Once the sealant has come in contact with the top section joint, the top section cannot be removed! Doing so will ruin the sealant's waterproof seal. If you must remove the top section, the entire joint sealant must be **removed and discarded**, new sealant must be installed per instructions and top section then reset on base section.

## **8. Anchoring the Tank**

- The tank must be anchored to the FuelVault floor per the Oldcastle drawings provided for this project.
- Use every floor anchor provided.
- It is important to use the stated size and design strength of straps, ropes, turnbuckles and hooks, etc., shown on the drawings.

## **9. Anti-Flotation Apron (Figure 6)**

(Applicable to Fuel Vaults designed in high watertable areas only)

If your Fuel Vault has been built with an anti-flotation apron, you have been supplied with a bundle of threaded rebar pieces, cut to the designed length at which your apron is poured.

Refer to your Oldcastle Precast Fuel Vault project drawings for specific apron dimensions.

Refer to Figure 6 for details on installing the apron.

- Insert a threaded rebar into every threaded insert in the galvanized keyway (Figure 6).
- Tie 2 (two) rebars parallel with all walls onto all rebar pieces, as shown on Oldcastle project drawings.



- Pour apron “in place” with 3,000 psi concrete (minimum 28 day strength) with slump <3”; thoroughly consolidate to form a continuous concrete apron completely around exterior of vault base section, at the width and depth shown on Oldcastle project drawings.

#### 10. **Backfilling and Compaction**

- Do the backfilling as soon as possible after the FuelVault structure has been placed and gasket and gasket material is fully compressed.
- Backfill materials may consist of good native soils which have been approved for use by an engineer, or other suitable materials such as pea gravel, crushed rock aggregate base course, etc.
- Bring up backfill material in even, proper lifts (layers) all the way around the structure using water and equipment to achieve the necessary relative compaction. Follow-up inspections for settlement are required.
- **NOTE:** Leaving the backfill level just below the lowest vault side hole penetration will allow workers to more easily install side and top pipes and wall sealant systems.
- **WARNING:** BE SURE TO DIVERT ALL WATER RUNOFF AWAY FROM THE FUELVAULT EXCAVATION DURING CONSTRUCTION; FAILURE TO DO SO COULD CAUSE DAMAGE TO THE TANK AND FUELVAULT, SHOULD FLOODING OCCUR.

#### 11. **Pipe Wall Seals** (Figure 3)

- A mechanical rubber pipe seal system is required to be used around every pipe which penetrates the FuelVault ceiling, side or end wall. Your FuelVault manufacturing plant has furnished you with a chart showing the pipe seal system brand name and model numbers for each pipe size, along with detailed manufacturers instructions on their proper installation.

Refer to Figure 3 for an explanation of this section.

NOTE: The brand name of pipe seal shown on your Oldcastle furnished project FuelVault drawings must be used; all hole penetrations were sized per this manufacturers sizing chart information; other seal brands may not properly seal the opening.

- Install the pipe seal flush with the interior surface of the vault.
- After all pipe seals are installed, pack the remaining portion of each pipe penetration hole with non-shrink grout; let dry thoroughly (24 hrs. min.)
- Apply a bituminous sealer (for concrete) over entire grout surface , overlapping onto FuelVault wall to seal penetration.
- OLDCASTLE PRECAST, INC. WILL NOT BE RESPONSIBLE FOR ANY BREACH OF SECONDARY CONTAINMENT VAULT DUE TO FAILURE OF THE MECHANICAL PIPE SEAL SYSTEM.

**12. Setting Riser Rings (Figure 4) (Applicable to below grade FuelVaults only)**

- If the top of your FuelVault is buried below grade, you were furnished with precast, reinforced concrete riser rings to bring the vault access manway(s) to finish grade.
- Thoroughly clean entire riser ring placement area; then apply sealant.
- Starting at the vault top surface, apply a ring of Oldcastle provided sealant approximately 3” away from the access opening, in a complete circle (see Figure 4); follow the application instructions as outlined in the section, “Installing the Joint Sealant”.
- Set first riser ring, bend the 2 lifting lugs outward, then apply another ring of sealant in the center of the first ring (Figure 4)
- Repeat this setting sequence until all riser rings are set in place.

**13. Setting Frames and Covers (Figure 4a)** (Applicable to below grade FuelVaults only)

- All frames have a galvanized steel skirt of at least 9” in height, permanently attached to the frame.
- The precast concrete rings previously set over each manway are designed to allow the galvanized skirt to slide inside the top riser ring; this enables the frame to be set at the exact final grade desired.
- Weld rebar pieces as required to the frame and/or skirt to hold it in place until final concrete surface slab is poured in place.

**14. Installing Access Ladders (Figure 5)**

- The non-ferrous ladder furnished with your FuelVault is specially designed to fit the width and height necessary to allow proper vault ingress and egress.
- Install a concrete threaded bolt anchor (properly sized to hold required load) in the FuelVault wall at each ladder standoff hole.(see Figure 5)
- DO NOT OVERDRILL HOLE DEPTH!! Doing so could jeopardize the integrity of the FuelVault, voiding the warranty.
- (For below grade FuelVaults only) The top ladder standoffs (in riser rings) are adjustable for a proper fit. Bolt these standoffs to the ladder and anchor to riser rings with bolt anchors

(see Figure 5).

- IMPORTANT NOTE: If you have field changed the bury depth of your FuelVault from what was originally designed, the ladder may not fit properly; consult your Oldcastle representative to refit the ladder, if necessary.

# Installing Joint Sealant

Figure 1

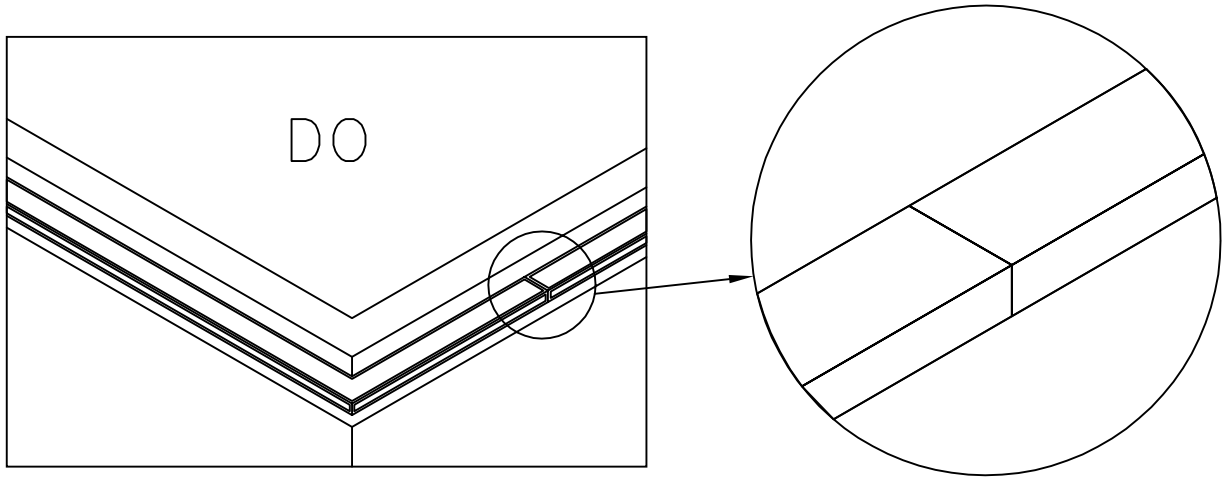

Be sure the seam is on a straight edge and that the two ends are KNEADED together.

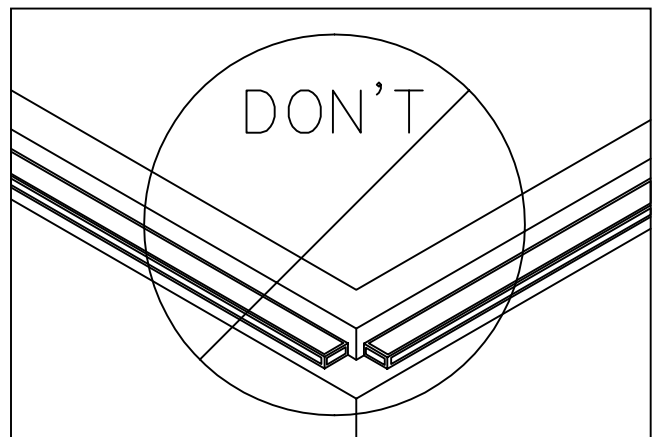
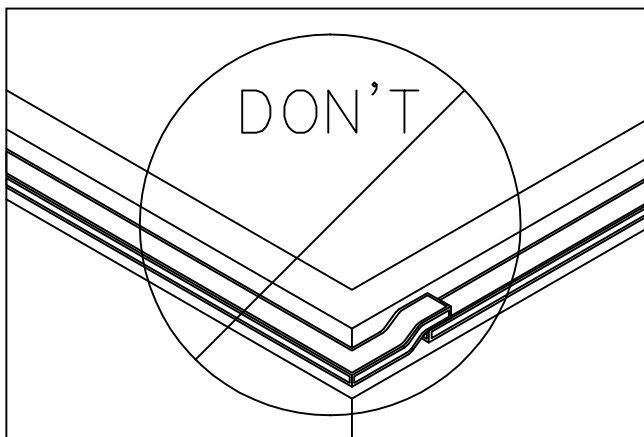

Oldcastle™  
FuelVaults



Oldcastle™ Precast, Inc.

# Installing Joint Sealant

Figure 1a

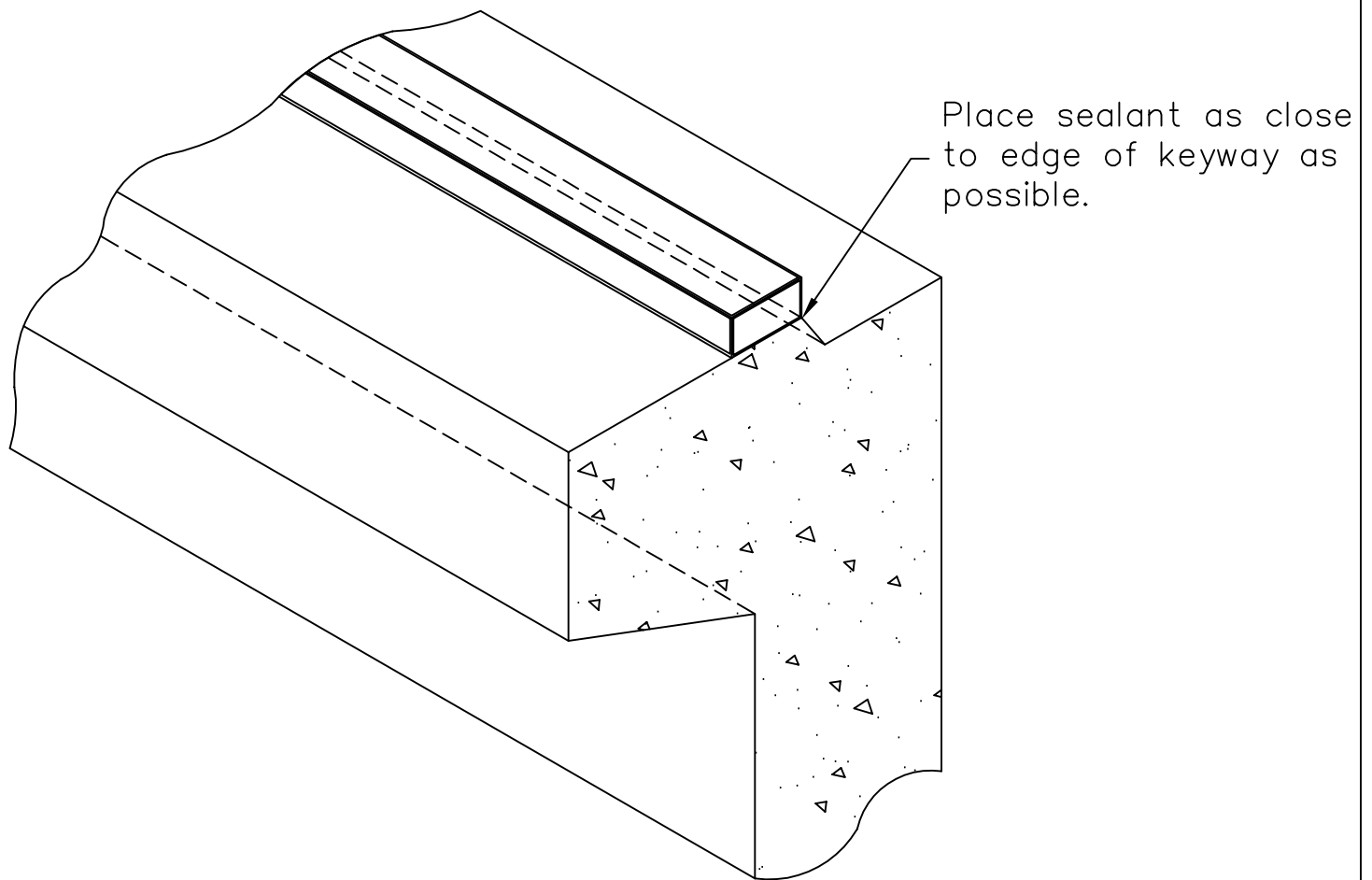

Oldcastle™  
FuelVaults™



Oldcastle™ Precast, Inc.

# Guide Angle Installation

Figure 2

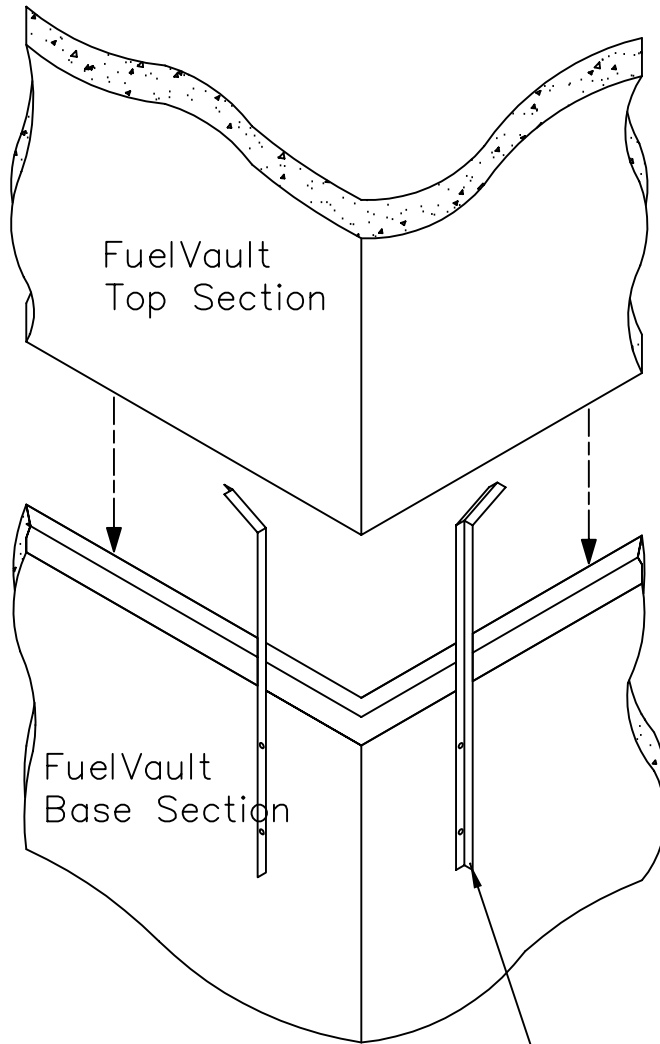

(4) Guide Angles Provided by OldcastlePrecast to be Installed on Diagonally Opposite Corners



Oldcastle™  
FuelVaults™



Oldcastle™ Precast, Inc.

# Mechanical Rubber Pipe Seal

Figure 3

## Subpump Sump Installation

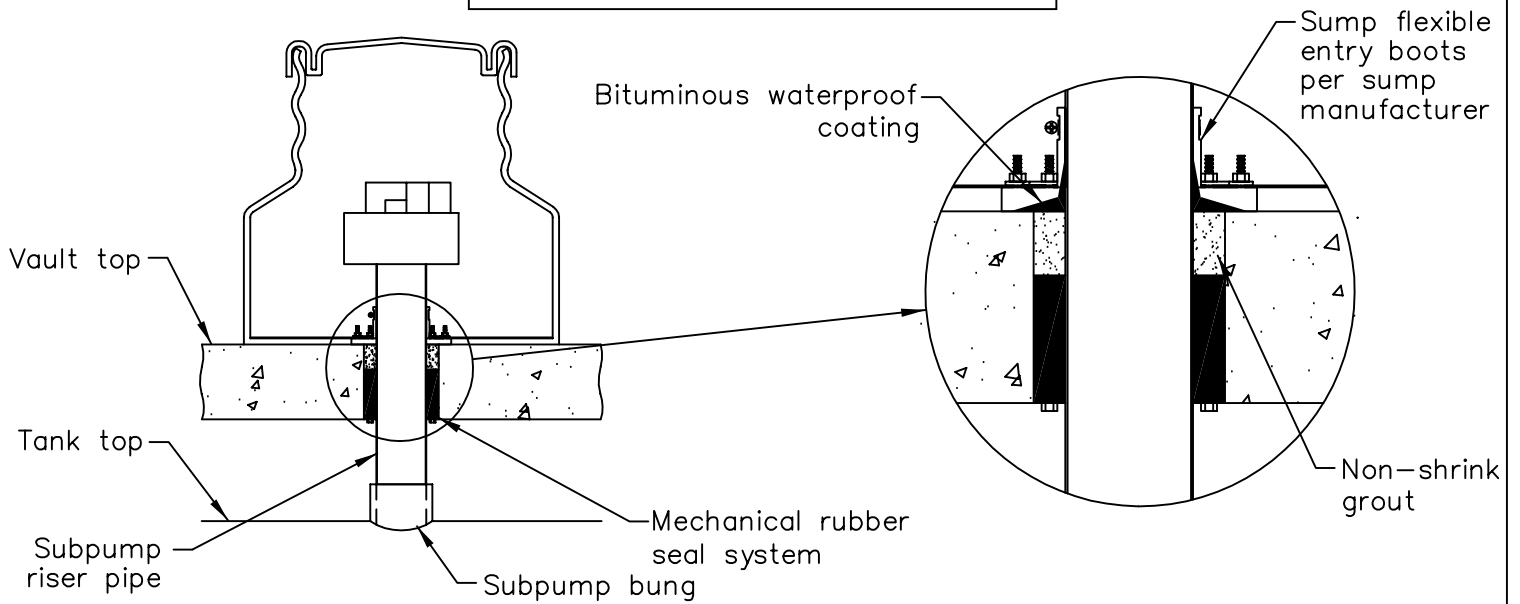

## Vault Top and Sidewall Pipe Penetration Installation

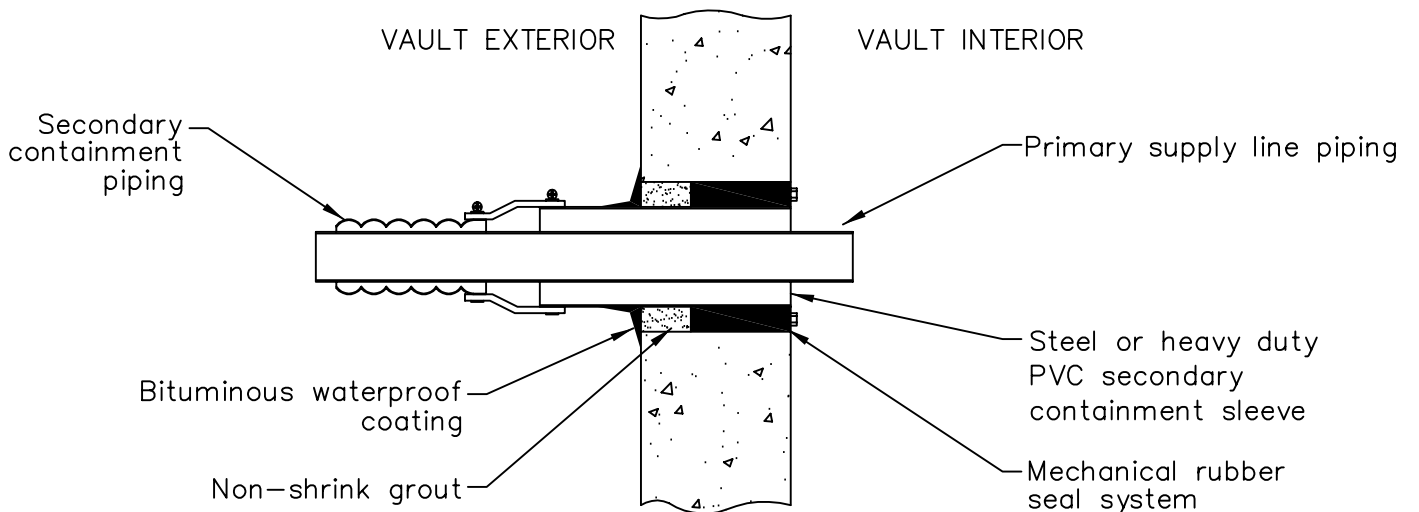

Oldcastle™  
FuelVaults™



Oldcastle™ Precast, Inc.

# Installing Riser Rings & Sealant

Figure 4

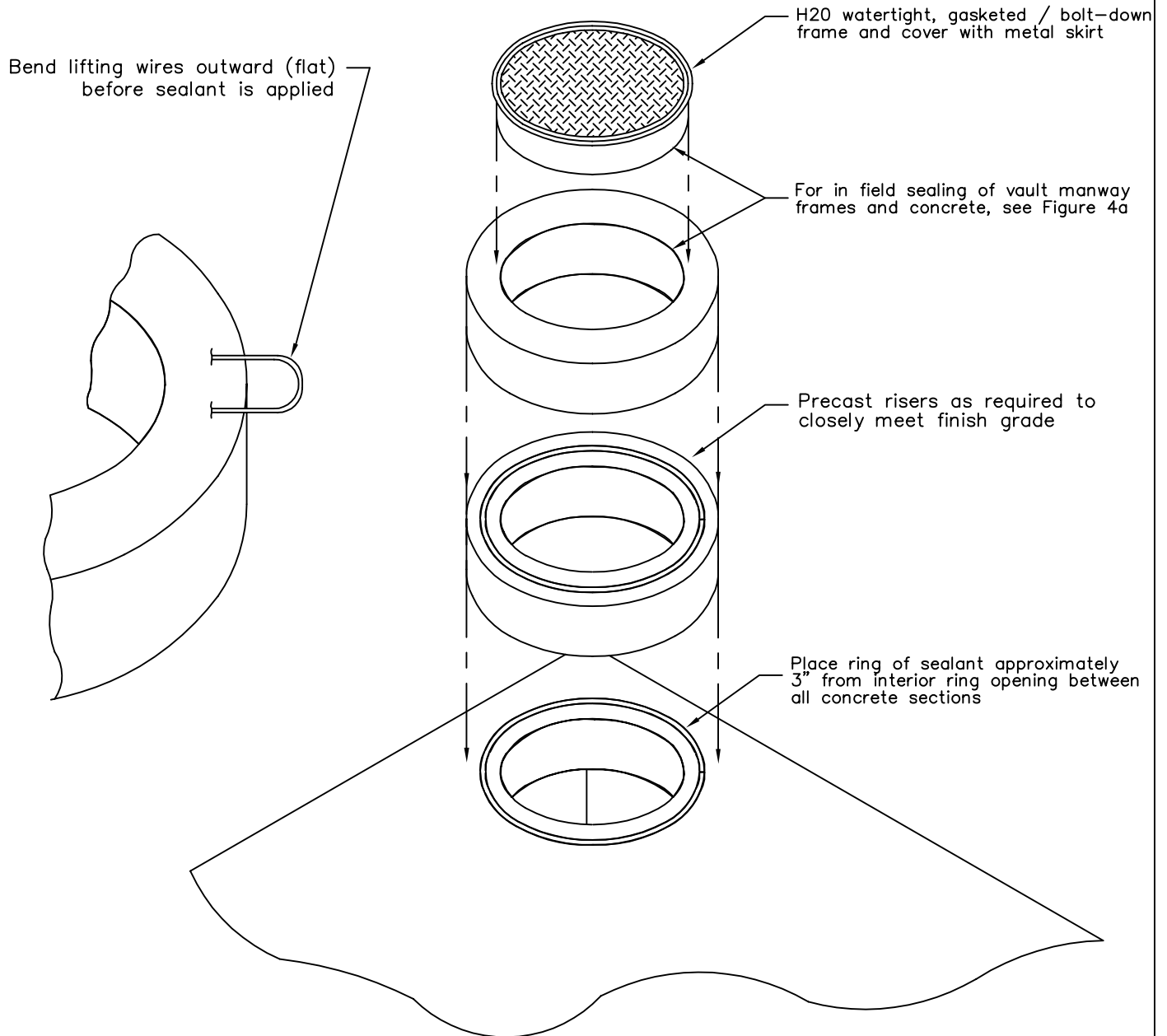

Oldcastle™  
FuelVaults™



Oldcastle™ Precast, Inc.



# Sealing Vault Access Manway Frames

Figure 4a

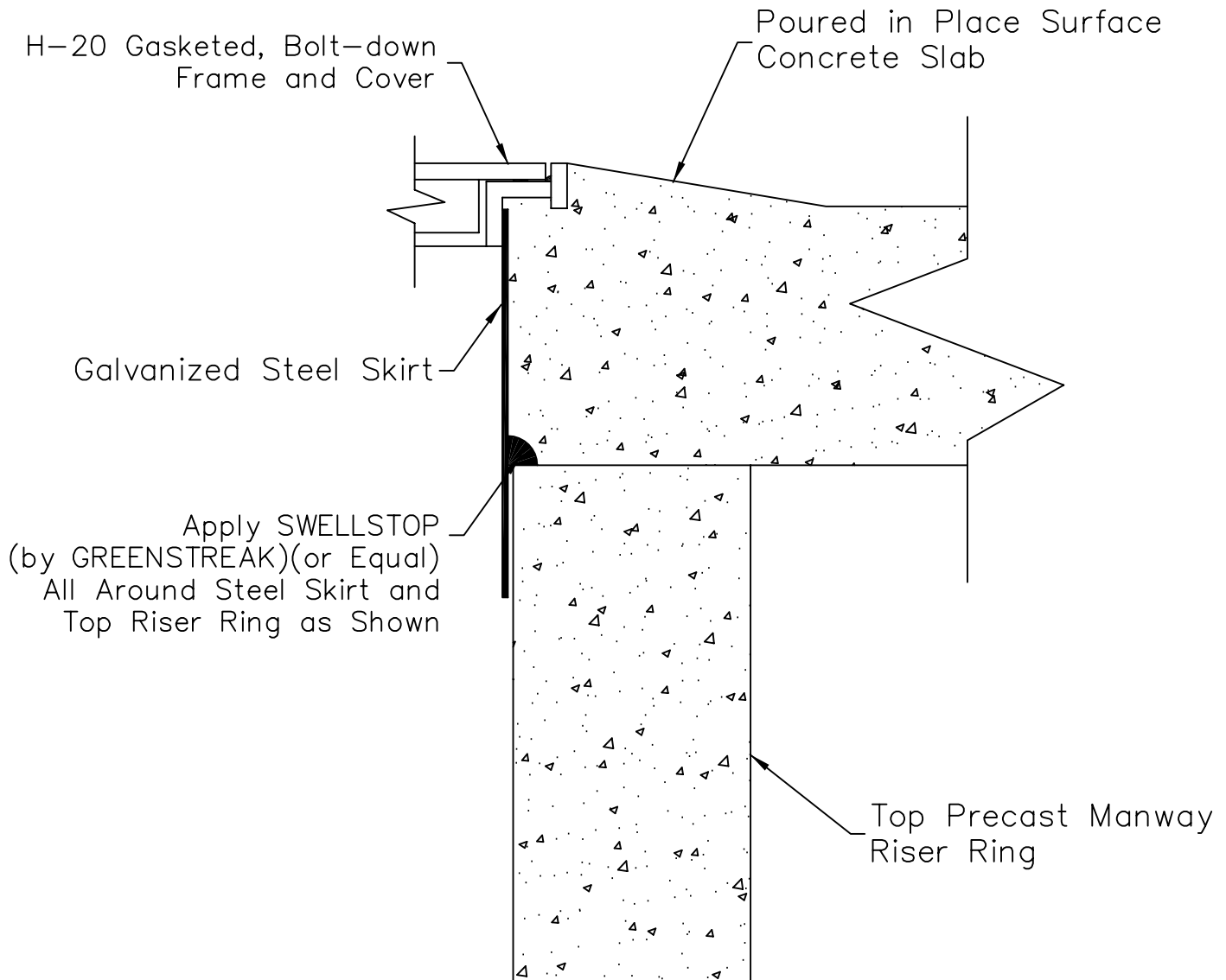

Oldcastle™  
FuelVaults™



Oldcastle™ Precast, Inc.

# Installing Ladders

Figure 5

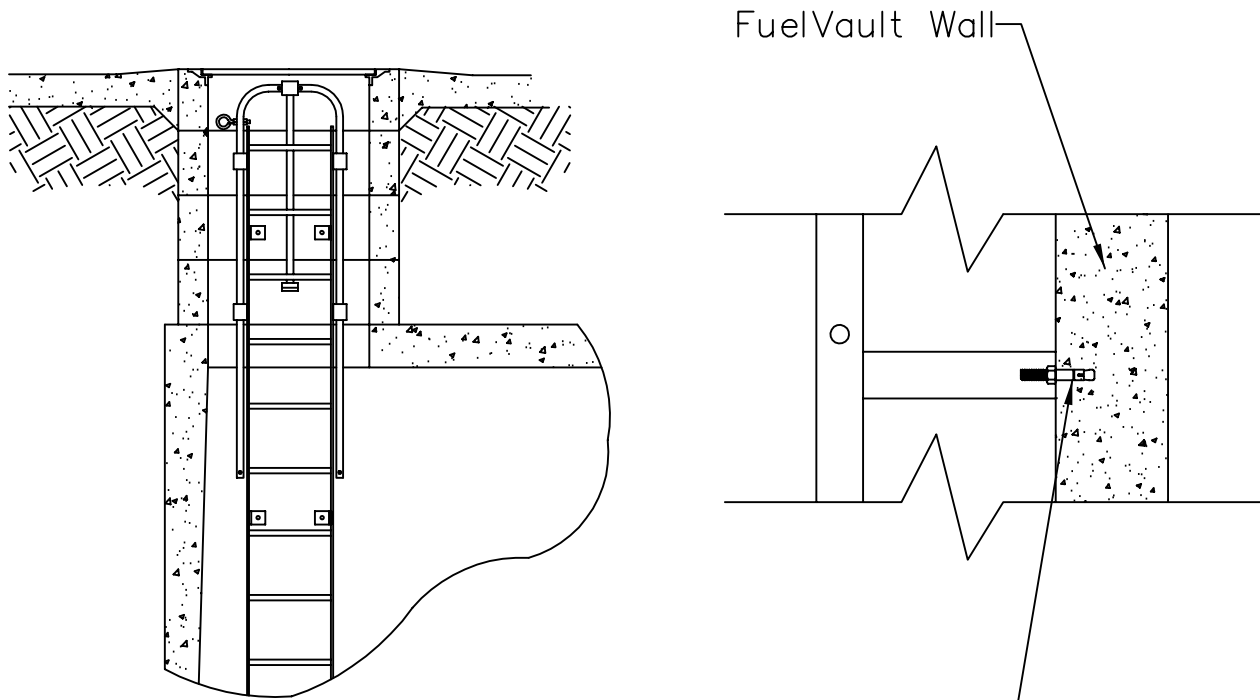

Drill FuelVault Wall 1 1/2" Maximum.  
Use WEJ-IT 3/8" x 2 3/4" Stainless  
Wedge Anchor Item No. ATS3823  
Or Equal. Install Anchors on ALL Standoffs.



Oldcastle™  
FuelVaults™



Oldcastle™ Precast, Inc.

# Anti-Flotation Apron Installation

Figure 6

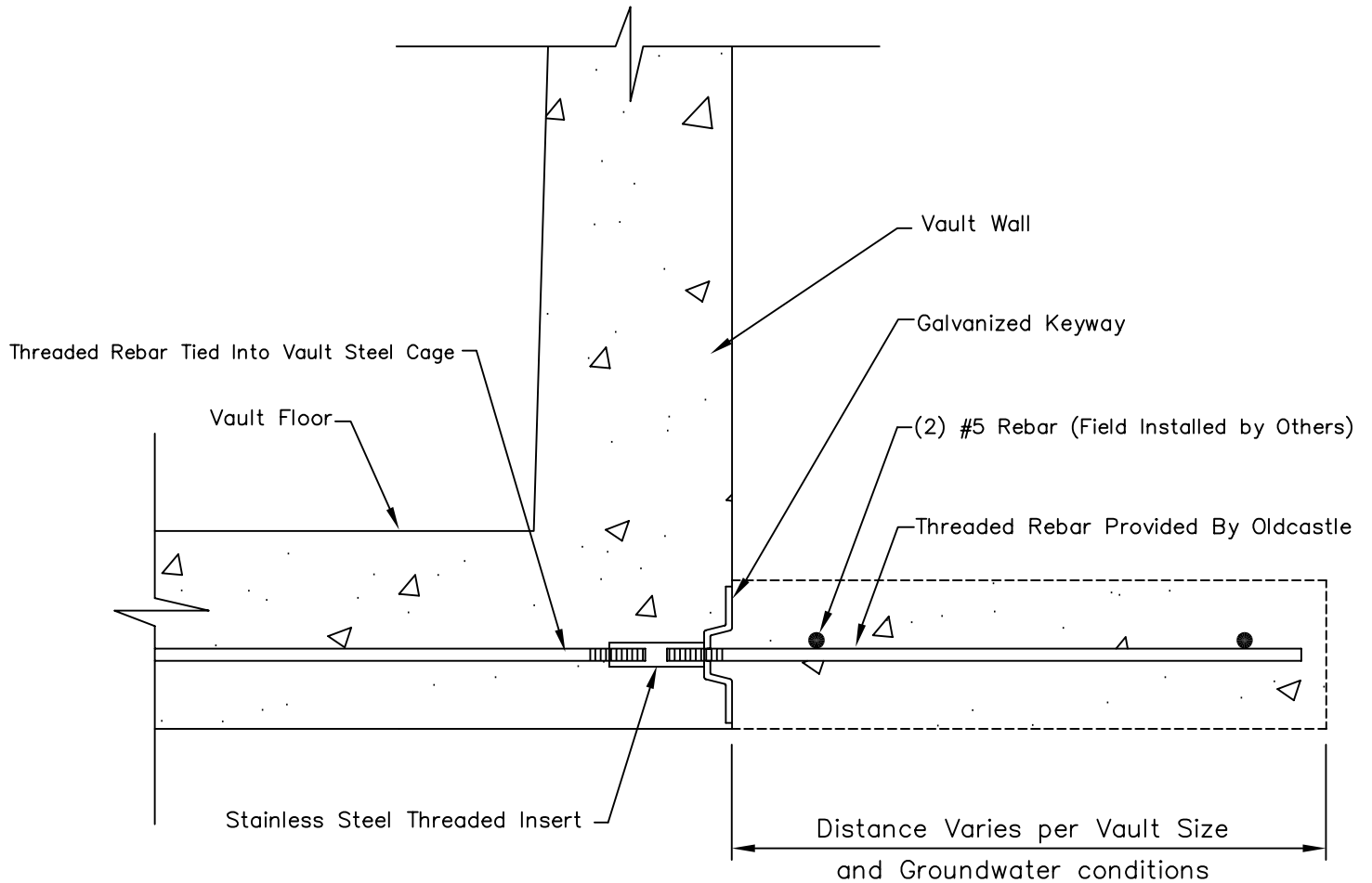

\* Oldcastle Will Provide Engineering Calculations To Determine Equilibrium Point.



Oldcastle™  
FuelVaults™



Oldcastle™ Precast, Inc.



**Oldcastle®**  
**FuelVaults™**

**OLDCASTLE PRECAST, INC.**  
**LIMITED STRUCTURAL WARRANTY**

Oldcastle Precast, Inc. (hereinafter called “Manufacturer”) manufactures below-grade concrete FuelVaults™ under the tradename “FuelVault™” which are designed to accommodate and contain tanks for the storage of Class 1 and Class 2 petroleum products (herein after called the “FuelVault™”).

A. Limited Structural Warranty

The Manufacturer makes the following LIMITED STRUCTURAL WARRANTY to the original purchaser (“Purchaser”) of a FuelVault™:

1. That each FuelVault™ is manufactured in accordance with the Manufacturer’s design specifications and criteria.
2. That the FuelVault™ will be free from structural defects in materials and workmanship for a period of twenty (20) years from the date of shipment to the Purchaser.

B. Limitations and Disclaimers

THE LIMITED STRUCTURAL WARRANTY CONTAINED HEREIN IS SUBJECT TO THE FOLLOWING CONDITIONS AND LIMITATIONS:

1. THIS LIMITED STRUCTURAL WARRANTY IS EXCLUSIVE AND IS GIVEN IN LIEU OF ANY AND ALL OTHER WARRANTIES, WHETHER THEY ARE WRITTEN, ORAL, EXPRESSED, IMPLIED, STATUTORY OR OTHERWISE, INCLUDING THE IMPLIED WARRANTIES OF MERCHANTABILITY AND/OR FITNESS FOR A PARTICULAR PURPOSE. THERE ARE NO OTHER WARRANTIES, LIMITED, EXPRESSED OR IMPLIED, WHICH EXTEND BEYOND THOSE CONTAINED HEREIN.
2. THIS LIMITED STRUCTURAL WARRANTY DOES NOT COVER DAMAGE TO THE FUELVAULT™ RESULTING FROM:
  - a. SHIPPING OR INSTALLATION
  - b. MISUSE OR ABUSE OF THE FUELVAULT™
  - c. ACTS OF GOD (INCLUDING, BUT NOT LIMITED TO, EARTHQUAKE, FLOOD AND SUBSIDENCE)
3. The following will void the Manufacturer’s LIMITED STRUCTURAL WARRANTY;
  - a. Storage of corrosive, toxic or other material other than Class 1 and Class 2 petroleum products, or other use of the FuelVault™ for purposes other than those expressed herein.
  - b. Failure to install the FuelVault™ in accordance with the “Oldcastle FuelVault Field Installation Manual” and the current most relevant provisions of the following in effect as of the date of this LIMITED STRUCTURAL WARRANTY; the Uniform Building Code; NFPA 30; NFPA 30A; and the Uniform Fire Code.
  - c. Failure to maintain and inspect the FuelVault™, tank and accessory equipment in accordance with all current codes and regulations.

- d. If persons other than the Manufacturer's personnel or those authorized in writing by the Manufacturer perform warranty work, repairs or modifications to the FuelVault™.
- e. Reassignment of this LIMITED STRUCTURAL WARRANTY by original Purchaser without express written permission of Manufacturer to do so.
- f. Failure to complete the "Oldcastle FuelVault Installation Checklist and Limited Structural Warranty Validation Certificate". Original signed copy of certificate must be submitted to Oldcastle Precast, Inc.

C. Sole Remedy

1. All claims for damage to the FuelVault™ and/or breach of the LIMITED STRUCTURAL WARRANTY contained herein shall be made in writing to the Manufacturer of the FuelVault™ within ten (10) days of the time the breach is discovered or should have been discovered. Warranty service must be performed by the Manufacturer or the Manufacturer's authorized agent. Upon validation by the Manufacturer of any claim for breach of the LIMITED STRUCTURAL WARRANTY contained herein, the Manufacturer will, at its sole and exclusive option, either:
  - a. Repair the defective FuelVault™; or
  - b. Deliver a replacement FuelVault™ to the point of original delivery by the Manufacturer; or
  - c. Refund the original purchase price of the FuelVault™.
2. The provisions contained in this Section "C" constitute Purchaser's sole and exclusive remedy under any claim or theory of liability, including any claim based upon failure of, or defect in the FuelVault™, whether such claim, however instituted, is based upon contract, indemnity, warranty, tort (including negligence), strict liability or otherwise. The manufacturer shall not be liable for direct, indirect, consequential damages or costs of any nature including, without limitation, labor costs of any kind relating to the removal of a failed FuelVault™ and/or installation of a replacement FuelVault™ or damages attendant thereto or claims or costs otherwise arising from, or in connection with, breach of this LIMITED STRUCTURAL WARRANTY.
3. The Manufacturer will not honor any claim under this LIMITED STRUCTURAL WARRANTY made prior to payment in full by the Purchaser for the FuelVault™.

D. Miscellaneous

1. This LIMITED STRUCTURAL WARRANTY is extended only to the Purchaser of the FuelVault™ from the Manufacturer and may not be assigned by such Purchaser to a third party without prior, written authorization of the Manufacturer.
2. The Manufacturer will not be responsible for costs or damages to the FuelVault™ or to Purchaser's property as a result of FuelVault™ inaccessibility or warranty repair, service or replacement.
3. In the event that a dispute arises between the Manufacturer and Purchaser over a claim submitted by the Purchaser for breach of this LIMITED STRUCTURAL WARRANTY, the Manufacturer and Purchaser agree that such dispute will be submitted to binding arbitration pursuant to the rules of the American Arbitration Association.
4. The arbitration of any dispute arising under this LIMITED STRUCTURAL WARRANTY must be commenced no later than one (1) year from the date the breach is discovered, or should have been discovered.
5. All accessories not of Oldcastle Precast, Inc. manufacture, such as ladders, frames and covers, mechanical pipe seals, ventilation fans, motors, etc., are not warranted by Oldcastle Precast, Inc. Some of these items may be warranted by the original manufacturer.
6. This LIMITED STRUCTURAL WARRANTY contains the complete understanding of the Manufacturer and Purchaser and may be modified only in writing signed by the President of the Manufacturer.



**OLDCASTLE FUELVAULT™ INSTALLATION CHECKLIST  
AND  
LIMITED STRUCTURAL WARRANTY VALIDATION CERTIFICATE**

This checklist must be completed in its entirety to validate the Oldcastle FuelVault™ Limited Structural Warranty. The installation contractor must read and follow the Installation Manual. Publication #FV-9701 provided with this checklist. The FuelVault™ owner must sign and return to Oldcastle this original document and must retain a copy of this document and the Oldcastle acknowledgment of receipt in order to substantiate any future structural warranty claim.

Date of Installation: \_\_\_\_\_ FuelVault™ Model No.: \_\_\_\_\_ Tank Size: \_\_\_\_\_

FuelVault™ UL#: \_\_\_\_\_ Tank UL#: \_\_\_\_\_

Site Owner: \_\_\_\_\_

Site Address: \_\_\_\_\_ City: \_\_\_\_\_ State: \_\_\_\_\_ Zip: \_\_\_\_\_

Installation Contractor: \_\_\_\_\_

Address: \_\_\_\_\_ City: \_\_\_\_\_ State: \_\_\_\_\_ Zip: \_\_\_\_\_

The following work has been completed and verified per the Oldcastle FuelVault™ Installation Manual:

**PRE-INSTALLATION**

Excavation size, including side wall and depth clearances have been checked \_\_\_\_\_

Compaction of native soil in bottom of excavation is properly completed \_\_\_\_\_

Imported bedding material is proper type and at depth required by Oldcastle \_\_\_\_\_

FuelVault™ base “footprint” has been marked on bedding surface \_\_\_\_\_

Visual inspection. No evidence of damage to FuelVault™ after removal of each section from trailer \_\_\_\_\_

**DURING INSTALLATION**

Visual inspection. No evidence of damage to FuelVault™ base section after setting in hole \_\_\_\_\_

Tank is set in FuelVault™ base at correct location, with bung layout in correct direction per drawings \_\_\_\_\_

Joint has been swept clean and sealant is properly applied to joint  
(It is critical that no debris be anywhere on the base and/or top FuelVault™ section's joint area) \_\_\_\_\_

FuelVault™ top section is set and seated correctly in base joint  
(This function requires an internal and external visual inspection of joint) \_\_\_\_\_

ANTI-FLOATATION APRON - (IF APPLICABLE)

Threaded rebar rods are installed in all base wall inserts and rebar tied to every rod per drawing \_\_\_\_\_

Ready-mix concrete is poured and thoroughly consolidated at base of walls of FuelVault™ at  
depth and width indicated on drawings \_\_\_\_\_

PIPING AND EQUIPMENT INSTALLATION

All piping mechanical rubber pipe seals, boots and connections, etc. through FuelVault™  
walls & top have been double checked for proper installation and tightness per product  
manufacturers instructions  
\_\_\_\_\_

All piping where mechanical rubber pipe seals are used and required in the FuelVault™ drawings,  
have been thoroughly grouted and coated from the outside of the FuelVault™ \_\_\_\_\_

Tank is properly anchored to FuelVault™ floor per drawings (if applicable) \_\_\_\_\_

Backfill materials is placed properly & compaction of material is sufficient to avoid future  
settlement around FuelVault™ structure \_\_\_\_\_

Concrete riser sections have been placed per drawings and each joint has been thoroughly  
swept clean and sealant properly applied \_\_\_\_\_

All equipment appurtenances anchors, penetrations, etc. have been thoroughly sealed from the  
exterior and (if necessary) interior of the FuelVault™ to prevent ground water infiltration into  
the structure \_\_\_\_\_

FuelVault™ access ladders have been properly placed and anchored using all attachment  
locations provided \_\_\_\_\_

Installation was in accordance with Oldcastle FuelVault™ Installation Manual, Publication #FV-9601.

Owner's Representative: \_\_\_\_\_ Title: \_\_\_\_\_ Date: \_\_\_\_\_

Owner's Phone #: \_\_\_\_\_

Contractor's Representative: \_\_\_\_\_ Title: \_\_\_\_\_ Date: \_\_\_\_\_

Contractor's Phone #: \_\_\_\_\_

**Note: Owner must retain a copy of this document to substantiate any further claim under the Oldcastle Precast, Inc. Limited Warranty, FuelVaultä .**