

RIGHT-SIDE VIEW

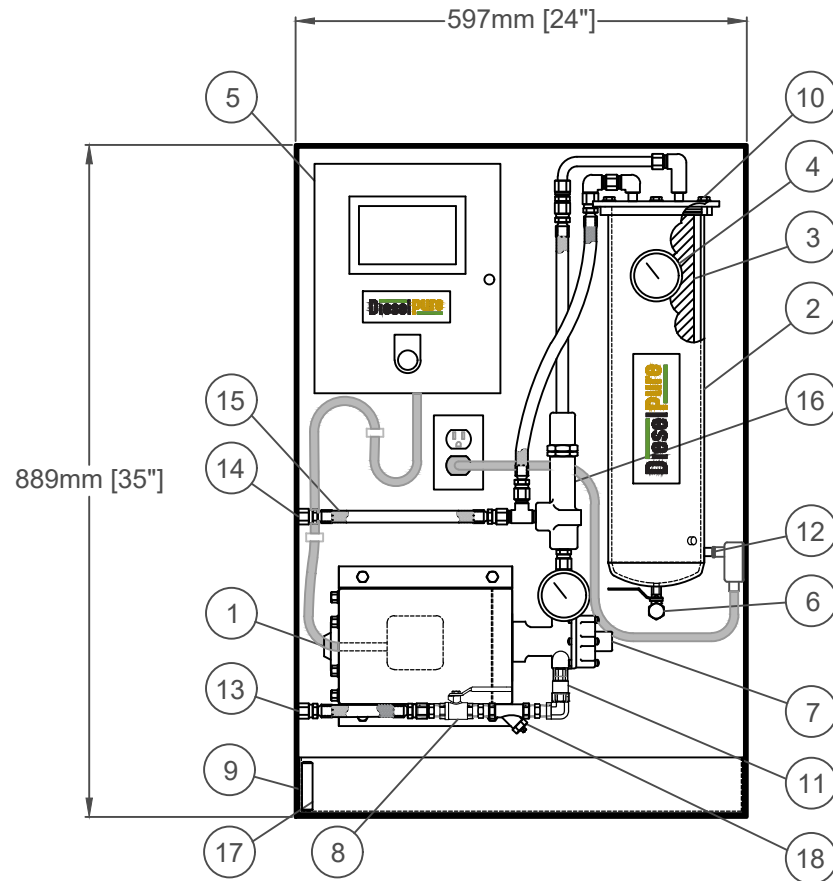

FRONT VIEW

NO.	DESCRIPTION
1	SINGLE PHASE 120 V 15 A MOTOR
2	ASME PRESSURE VESSEL
3	DIESELPURE COALESCING ELEMENT
4	LIQUID FILLED PRESSURE GAUGES
5	CONTROL PANEL (C.S.A. APPROVED)
6	PRESSURE VESSEL WATER DRAIN
7	CONTINUOUS DUTY GEAR PUMP
8	FUEL INLET ISOLATION VALVE
9	DRIP TRAY
10	LID BOLTS
11	CHECK VALVE
12	OPTIONAL HEATER - 120 V OUTLET
13	FUEL INLET/SUCTION
14	FILTERED FUEL OUTLET
15	STAINLESS STEEL BRAIDED FLEXLINE - JIC CONNECTIONS
16	PRESSURE BYPASS VALVE
17	DRIP TRAY FLOAT SWITCH
18	'Y' STRAINER

INSTALLATION NOTES:

- A. EXTERNAL PIPE TO BE MECHANICALLY PROTECTED.
- B. USE MINIMUM NUMBER OF JOINTS POSSIBLE.
- C. SUCTION LINE MAY REQUIRE ADDITIONAL ANTI-SYPHON DETAILS.
- E. 120 V SINGLE PHASE DEDICATED 15 A CIRCUIT IS REQUIRED FOR OPTIONAL IMMERSION HEATER.



www.core-es.com
800.628.5502



100 SERIES

DieselPure Inc. - Tel:1-800-901-0078 - www.DieselPure.com

DATE: 02/26/17 - DRAWN BY: A.SCOTT - SCALE: 1:10