



TECHNICAL SERVICE MANUAL

SECTION	TSM 340
PAGE	1 OF 10
ISSUE	G

INSTALLATION, START UP, TROUBLESHOOTING, PREVENTIVE MAINTENANCE, DO'S & DON'TS SERIES SG-04, SG-05 & SG-07 SPUR GEAR PUMPS

CONTENTS

Installation	1
Mounting	2
Start Up	3
Troubleshooting	6
Miscellaneous	8
Do's and Don'ts	9
Warranty	10

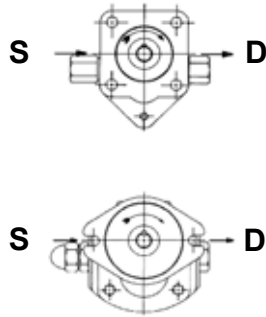

FIGURE 1

INSTALLATION

General

The following items must be considered prior to pump installation:

1. Location - locate the pump as close as possible to the liquid supply. If possible locate the pump below the liquid supply. Viking pumps are self-priming; but the better the suction conditions, the better the pump will perform.
2. Accessibility – the pump must be accessible for inspection, maintenance and repair.
3. Suction/Discharge - SG Series pumps are designed for clockwise rotation as standard (viewed from end of shaft). Refer to Figure 1.
4. Pressure Relief Valve - the SG Series is a positive displacement pump and requires some form of over pressure protection. Without pressure protection, if the discharge line is blocked or becomes closed, pressure will build up until the motor stalls, drive equipment fails, a pump part breaks, or the piping and/or other equipment in the system bursts. To prevent the possibility of any one or more of the above from occurring, the use of a pressure relief valve is recommended.
5. Storage - drain the pump and apply a light coat of non-detergent SAE 30 weight oil to all internal pump parts. Apply grease to the pump shaft extension. Viking suggests rotating the pump shaft by hand one complete revolution every 30 days to circulate the oil.

MOUNTING

1. Surfaces to which the pump mounts must be clean and flat.
2. Use SAE Grade 5 or better capscrews to mount pump.
3. The 4 mounting capscrews for the SG-04 and SG-05 pumps must have a minimum of ½ inch thread engagement, and must be torqued evenly to 12-15 ft-lbs.
4. The 2 mounting capscrews for the SG-07 pumps must have a minimum of ½ inch thread engagement, and be evenly torqued to 50-55 ft-lbs.
5. Standard SG Series pumps are designed to be used with jaw type couplings that do not induce axial thrust on the pump shaft. If an improper type of coupling is used, internal damage may result.
6. Do not strike or press the pump drive coupling to install. Internal pump damage will result. If the coupling does not slide onto the shaft, inspect the coupling, shaft and key for nicks or burrs and remove.
7. If the pump is to be belt or gear driven, the overhung load option must be specified.
8. Once the pump has been mounted and the coupling installed, it is recommended to put lube oil into the suction port and turn the pump by hand to make sure it turns freely.

Alignment

Check alignment after mounting.

1. If the unit has a flexible coupling, remove any coupling guards or covers and check alignment of coupling halves. A straight edge (piece of key stock will work) across the coupling must rest evenly on both rims at the top, bottom and sides. See Figure 3.
2. Make a final check on alignment after the piping is hooked up.

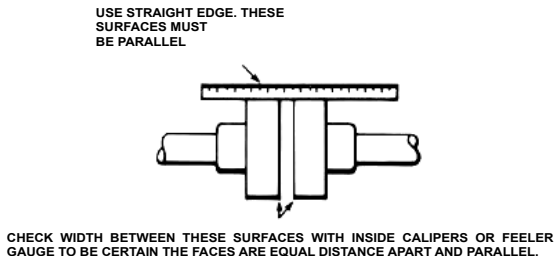

FIGURE 3

Piping/Hose

The cause of many pumping problems can be traced to the suction piping. It should always be as large in diameter and as short in length as possible.

Before starting the layout and installation of your piping system, consider the following points:

1. Never use piping smaller than the pump port connections. Piping larger in diameter than the port connection is sometimes required to reduce friction losses.

2. Be sure the inside of the pipe is clean before installing.
3. When approaching an obstacle to the suction line, go around instead of over it. Going over an obstacle can create an air pocket. Where practical, slope the piping so no air or liquid pockets will be formed. Air pockets in the suction line make it hard for the pump to prime.
4. A strainer on the suction side of the pump should always be considered in any pumping system. The strainer will keep foreign matter from entering the pump. The strainer mesh or perforation size should be large enough so that it does not cause excessive pressure drop, but fine enough to protect the pump. Use of a strainer is particularly important at start up to help clean the system of weld beads, pipe scale and other foreign objects.
5. A pressure relief valve is required in the discharge line. See Pressure Relief Valves, General page 1 item 4.
6. The pump must not be used to support the piping. Hangers, supports, stands, etc. must carry the weight of the pipes.
7. When fastening piping to the pump do not impose any strain on the pump casing. "Springing" or "drawing" the piping up to the pump will cause distortion, possible misalignment and probable rapid wear of the pump. Do not use the pump to correct errors in piping layout or assembly.
8. All joints of piping system must be tight; liquid thread sealant will help assure leak free threaded joints. Loose joints result in liquid leaks or suction side leaks. Air leaks make the pump noisy and reduce flow. **CAUTION:** Be careful not to over tighten fittings as this can cause cracked joints. Do not use PTFE tape. Reduced friction makes over tightening very easy and will result in cracked ports. Leaks in the suction line can permit air to be drawn in, and will cause a noisy pump and reduction in capacity.
9. Drive alignment must be checked after piping is hooked up.
10. Provide a pressure relief device in any part of a pump and piping system that can be valved off and, thus, completely isolated. A rise in temperature will cause a liquid to expand. If there is no provision for pressure relief in the closed off section, there is a chance that the pump or piping will rupture.

Danger !

**Before starting pump, be sure all drive equipment guards are in place.
Failure to properly mount guards may result in serious injury or death.**

START UP

Before pushing "start" button, check the following:

1. Are vacuum and pressure gauges (liquid filled) mounted on or near the pump? Gauges are the quickest and most accurate way of finding out what is happening in the pump.
2. Is the pump is correctly aligned with the drive equipment?
3. Make sure there is no pipe strain on the pump ports.
4. Rotate the pump shaft by hand to be sure it turns freely.

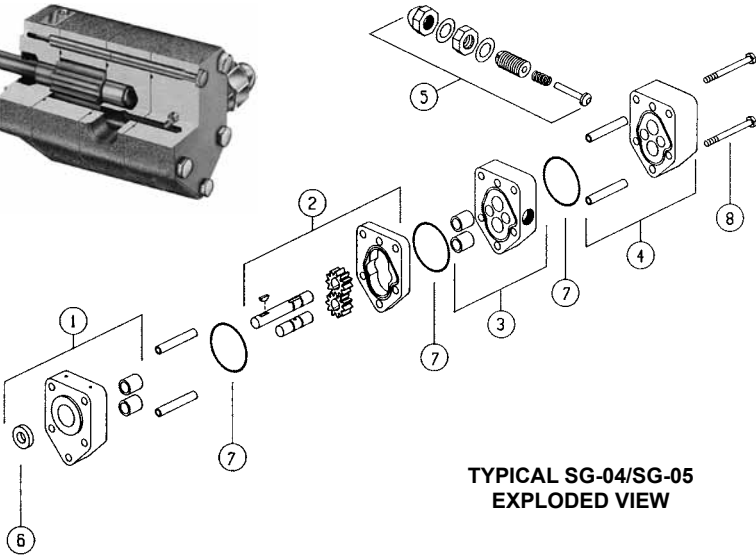

**TYPICAL SG-04/SG-05
EXPLODED VIEW**

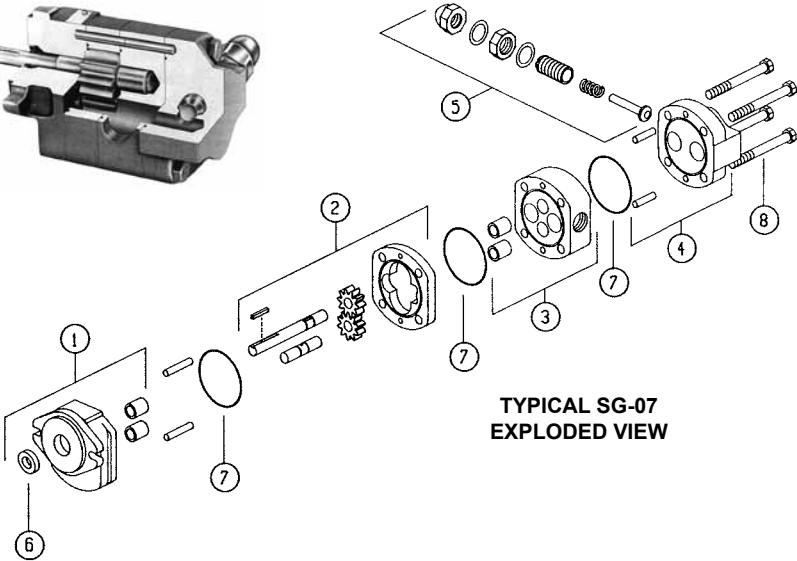

**TYPICAL SG-07
EXPLODED VIEW**

ITEM	DESCRIPTION	ITEM	DESCRIPTION
1.	Bracket, lipseal & bearing section	5.	Relief valve kit
2.	Match ground casing & (2) gears, driver & driven shafts	6.	Lipseal
3.	Separation plate & bearing assy.	7.	O-ring
4.	Head and alignment sleeve assy.	8.	Assembly cap screws

5. Before connecting to the motor, jog it to be sure it is running in the correct direction. Refer to “**General**” on page 1.
6. Is the pressure relief valve installed properly?
7. Make sure suction piping is properly connected and sealed, and valves are open.
8. Make sure the discharge piping is properly connected and sealed, valves are open, and there is a place for the liquid to go.
9. Make sure all guards are in place.
10. The above checklist is a general guideline to be used prior to starting the pump. Since Viking Pump cannot foresee every application for our product and possible system design, the final responsibility is with the user. The pump must be utilized within the catalog specifications and the pump system must be designed to provide safe working conditions.

The “start” button may now be pushed.

The pump should begin to deliver liquid within 15 seconds! If not, push the stop button. Do not run the pump without liquid flow longer than 30 seconds or the pump may be ruined.

Review **Startup** steps 1 through 10. Consider what the suction and discharge gauges may indicate. If everything appears in order, re-prime pump. Refer to **Mounting**, page 2, item 8.

Push the “start” button. If nothing is flowing within 30 seconds, stop the pump. The pump is not a compressor, it will not build up much air pressure. It may be necessary to vent discharge line until liquid begins to flow.

If pump still does not deliver, consider one or more of the following:

1. The suction line has air leaks.
2. The end of the suction pipe is not submerged deeply enough in the liquid.
3. The suction lift is too great or the suction piping is too small.
4. Liquid is vaporizing in the suction line before it gets to the pump.

If after consideration of these points, the pump still does not deliver liquid, review all points given under **START UP** and read through the **TROUBLESHOOTING** guide and try again. If pump still will not deliver liquid, contact your Viking Pump supplier.

TROUBLESHOOTING

A Viking pump that is properly installed and maintained will give long satisfactory performance.

If trouble does develop, one of the first steps toward finding the difficulty is to install a vacuum gauge in the suction line and a pressure gauge in the discharge line. Readings on these gauges often give a clue on where to start looking for trouble.

DANGER !

Before opening any Viking pump liquid chamber (pumping chamber, reservoir, relief valve adjusting cap fitting etc.) be sure:

- 1. That any pressure in chamber has been completely vented through the suction or discharge lines or other appropriate openings or connections.**
- 2. That the driving means (motor, turbine, engine, etc.) has been “locked out” or made non-operational so that it cannot be started while work is being done on the pump.**
- 3. That you know what liquid the pump has been handling and the precautions necessary to safely handle the liquid. Obtain a material safety data sheet (MSDS) for the liquid to be sure these precautions are understood.**

Failure to follow the above listed precautionary measures may result in serious injury or death.

Vacuum Gauge - Suction Port

High vacuum reading would indicate:

1. The suction line is blocked, valve closed, a strainer is plugged or a pinched suction line.
2. The suction line is too small.
3. The liquid is too viscous to flow through the piping.
4. The lift required is too high.

Low reading would indicate:

1. There may be an air leak in the suction line.
2. The end of the pipe is not in the liquid.
3. The pump is worn.
4. The pump is dry and should be primed.

Flutter, jumping or erratic reading would indicate:

1. The liquid is vaporizing.
2. Liquid is coming in to the pump in slugs, possibly an air leak or insufficient liquid above the end of the suction pipe.
3. Vibration from cavitation, misalignment, or damaged parts.

Pressure Gauge - Discharge Port**High reading would indicate:**

1. High viscosity and small diameter and/or lengthy discharge line.
2. The strainer or filter is plugged.
3. The pressure relief valve is set too high.
4. Valve in the discharge line partially closed.
5. Line partially plugged from build up on inside of pump, solidified product or foreign object.
6. Liquid in the pipe not up to temperature.

Low reading would indicate:

1. Pressure relief valve set too low.
2. Pressure relief valve poppet not seating properly.
3. Pump mounting capscrews into torqued to specifications (GP-04 and GP-05 Series 12-15 ft.-lbs.).
4. Pump assembly bolts not torqued into specifications (GP-07 Series 50-55 ft.- lbs.).
5. The bypass around pump partially open.
6. Pump is damaged or worn.
7. The pump has too much internal clearance.

Flutter, jumping or erratic reading would indicate:

1. Cavitation.
2. Liquid is coming to the pump in slugs.
3. Air leak in the suction line.
4. Vibrating from misalignment or mechanical problems.

MISCELLANEOUS

Pump does not pump:

1. The pump has lost its prime from air leak or low level in tank.
2. The suction lift is too high.
3. Rotating in the wrong direction.
4. The motor does not come up to speed.
5. The strainer is clogged.
6. The bypass valve is open, pressure relief valve set too low or pressure relief valve poppet stuck open.
7. The pump is worn out.
8. Any changes in liquid, system or operation that would help explain the trouble, e.g. new liquid, additional lines or process changes.

Pump starts, then loses its prime:

1. The supply tank is empty.
2. The liquid is vaporizing in the suction line.
3. There is an air leak or air pockets in the suction line.
4. The pump is worn out.

Pump is noisy:

1. The pump is cavitating (liquid vaporizing in suction line) or being starved (heavy liquid cannot get to pump fast enough). Increase the suction pipe size and/or reduce the length, or decrease the pump speed. If the pump is above the liquid, raise the liquid level closer to the center line of the inlet port. If the liquid is above the pump, increase the head of the liquid.
2. Check alignment.
3. Anchor the base or piping to eliminate vibration.

Pump not delivering up to capacity:

1. The pump is starving or cavitating – see **Pump is noisy**, item 1.
2. The strainer partially clogged.
3. Air leak somewhere in the suction line.
4. Running too slow. Is the motor the correct speed and wired up correctly?
5. Pressure relief valve is set too low, stuck open or has damaged poppet seat.
6. The bypass line around the pump partially opened.
7. The pump is worn out.

Pump takes too much power (stalls motor):

1. The pump sequence valve set too high.
2. Liquid is more viscous than the is unit sized to handle.
3. The system pressure relief valve set too high.
4. The pump is misaligned.

DO'S AND DON'TS

Do's and Don'ts for installation, operation and maintenance of Viking pumps to assure safe, long, trouble free operation.

Installation:

1. **DO** install the pump as close to supply tank as possible.
2. **DO** leave working space around the pumping unit.
3. **DO** use large, short and straight suction port.
4. **DO** install a strainer in the suction line.
5. **DO** a double check of alignment after unit is mounted and piping is hooked up.
6. **DO** provide pressure relief valve for discharge side of pump.
7. **DO** check for proper rotation.
8. **DO** use a return line filter.
9. **DO** use an industrial grade hydraulic oil.
10. **DO** use piping, hose and fittings rated for maximum system pressure.

Operation

1. **DON'T** run the pump at speeds faster than 3600 RPM.
2. **DON'T** allow the pump to develop pressure higher than those shown in catalog at that size.
3. **DON'T** operate pumps at temperatures above or below limits shown in catalog for model.
4. **DON'T** operate unit without all guards in place.
5. **DON'T** operate pump without pressure relief valve in discharge piping; be sure valve is mounted and set correctly.
6. **DON'T** stick fingers in ports of pump!!! Fingers may be pinched between gears.
7. **DON'T** work on the pump unless driver has been "locked out" so it cannot be started while work is being done on the pump.

Maintenance:

1. **DO** record pump model number and serial number and file for further use.
2. **DO** have spare parts, pump or stand by units available, particularly if pump is essential part of key operation process.
3. **DO** obtain, read and keep all maintenance instructions furnished with pump.
4. **DO** make sure any pump that has residual system pressure in it or that has handled high vapor pressure liquids, has been vented through the suction or discharge lines or other openings provided for this purpose.
5. **DO** make sure that if the pump is still hooked to the driver while maintenance is being performed that the driver has been "locked out" so that it cannot be inadvertently started while work is being done on the pump.
6. **DO** make sure any pump that has handled a corrosive, flammable, hot or toxic liquid has been drained, flushed, vented and/or cooled before it is disassembled.

**VIKING
PUMP**

**TECHNICAL SERVICE
MANUAL**

SECTION	TSM 340
PAGE	10 OF 10
ISSUE	G

**INSTALLATION, START UP, TROUBLESHOOTING,
PREVENTIVE MAINTENANCE, DO'S & DON'TS
SERIES SG-04, SG-05 & SG-07 SPUR GEAR PUMPS**

**VIKING
PUMP**

**IDEX
CORPORATION**

WARRANTY

Viking warrants all products manufactured by it to be free from defects in workmanship or material for a period of one (1) year from date of startup, provided that in no event shall this warranty extend more than eighteen (18) months from the date of shipment from Viking. The warranty period for Universal Seal series pumps ONLY (Universal Seal models listed below) is three (3) years from date of startup, provided that in no event shall this warranty extend more than forty-two (42) months from the date of shipment from Viking.

UNDER NO CIRCUMSTANCES SHALL VIKING BE LIABLE UNDER THIS WARRANTY OR OTHERWISE FOR SPECIAL, INCIDENTAL, INDIRECT, CONSEQUENTIAL OR PUNITIVE DAMAGES OF ANY KIND, INCLUDING, BUT NOT LIMITED TO, LOST OR UNREALIZED SALES, REVENUES, PROFITS, INCOME, COST SAVINGS OR BUSINESS, LOST OR UNREALIZED CONTRACTS, LOSS OF GOODWILL, DAMAGE TO REPUTATION, LOSS OF PROPERTY, LOSS OF INFORMATION OR DATA, LOSS OF PRODUCTION, DOWNTIME, OR INCREASED COSTS, IN CONNECTION WITH ANY PRODUCT, EVEN IF VIKING HAS BEEN ADVISED OR PLACED ON NOTICE OF THE POSSIBILITY OF SUCH DAMAGES AND NOTWITHSTANDING THE FAILURE OF ANY ESSENTIAL PURPOSE OF ANY PRODUCT.

THIS WARRANTY IS AND SHALL BE VIKING'S SOLE AND EXCLUSIVE WARRANTY AND SHALL BE IN LIEU OF ALL OTHER WARRANTIES, EXPRESS OR IMPLIED, INCLUDING, BUT NOT LIMITED TO, ALL WARRANTIES OF MERCHANTABILITY, FITNESS FOR A PARTICULAR PURPOSE AND NON-INFRINGEMENT ALL OF WHICH OTHER WARRANTIES ARE EXPRESSLY EXCLUDED.

See complete warranty at www.vikingpump.com.

**IDEX
CORPORATION**

VIKING PUMP, INC. • A Unit of IDEX Corporation • Cedar Falls, IA 50613 USA

© 3/2013 Viking Pump Inc. All rights reserved